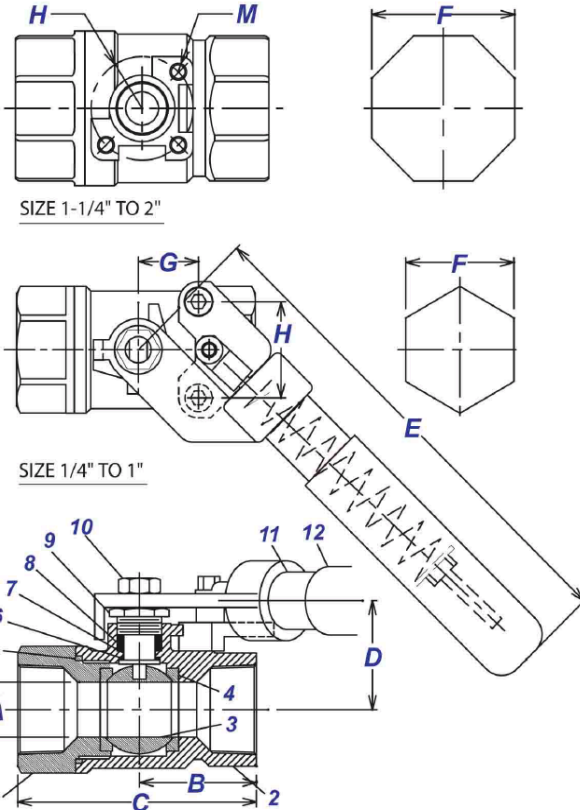
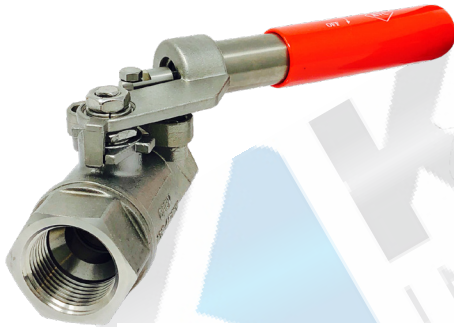

FIG. SPR-BV:

TWO-PIECE 2000 PSI THREADED ENDS SPRING RETURN

Features:

- Investment Casting
- Floating Ball
- NPT Threads: ANSI B1.20.1
- Adjustable Packing Nut
- Blowout Proof Stem
- Deadman Handle
- Complies to NACE MR-0103 / MR0175
- 1/4" ~ 1/2" – Full Port
- 3/4" ~ 2" – Reduced Port



Materials List:

No.	Part Name	Specification
1	Body	CF8M
2	Cap	CF8M
3	Ball	CF8M
4	Ball seat	PTFE + 15% GF
5	Joint gasket	PTFE
6	Thrust washer	PTFE + 15% GF
7	Stem	ANSI 316
8	Stem packing	PTFE + 15% GF
9	Gland nut	A194 Gr. 8
10	Stem nut	A194 Gr. 8
11	Spring handle	ANSI 304
12	Handle cover	Plastic

Test Pressure:	Shell	Seat
Hydrostatic	3000 psi	2200 psi
Air	-	85 psi

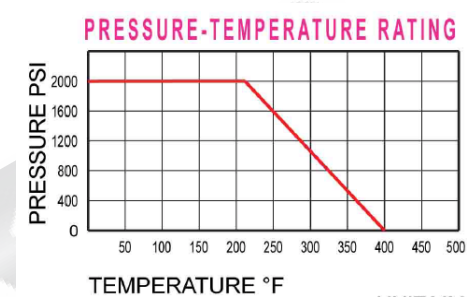

Dimension:

Size		A		B		C		D		E		F		G		H		M		Weight	
in	mm	in	mm	in	mm	in	mm	in	mm	in	mm	in	mm	in	mm	in	mm	mm	lbs	kgs	
1/4	6	0.43	11.00	1.08	27.50	2.30	58.50	1.18	30.00	7.13	180	0.94	24	0.50	12.70	1.12	28.50	M6*1	1.57	0.71	
3/8	10	0.49	12.50	1.08	27.50	2.30	58.50	1.18	30.00	7.13	180	0.94	24	0.50	12.70	1.12	28.50	M6*1	1.55	0.70	
1/2	15	0.49	12.50	1.12	28.40	2.56	65.00	1.18	30.00	7.13	180	1.06	27	0.50	12.70	1.12	28.50	M6*1	1.42	0.65	
3/4	20	0.59	15.00	1.48	37.50	3.03	77.00	1.47	37.30	7.13	180	1.26	32	0.87	22.10	1.37	34.80	M6*1	2.41	1.10	
1	25	0.79	20.00	1.69	43.00	3.41	86.50	1.56	39.50	7.13	180	1.61	41	0.87	22.10	1.37	34.80	M6*1	2.68	1.22	
1 1/4	32	0.98	25.00	1.81	46.00	3.90	99.00	2.11	53.50	10.8	275	1.97	50	-	-	1.97	Ø50	M8*1.25	4.33	1.97	
1 1/2	40	1.26	32.00	2.02	51.50	4.06	103.00	2.27	57.70	10.8	275	2.36	60	-	-	1.97	Ø50	M8*1.25	5.65	2.57	
2	50	1.49	38.00	2.44	62.00	4.88	124.00	2.54	64.50	10.8	275	2.76	70	-	-	1.97	Ø50	M8*1.25	6.50	2.95	