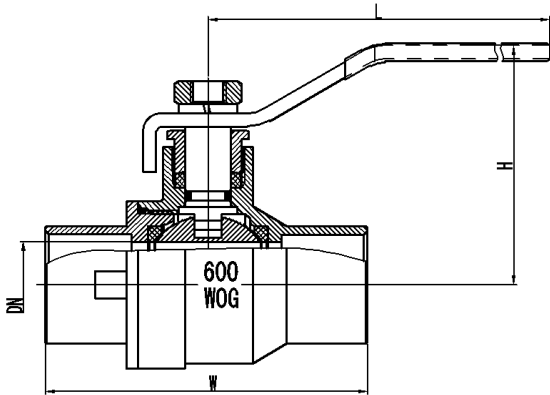

FIG. 100C

600 WOG FULL PORT FORGED BRASS BALL VALVE SOLDER JOINT ENDS



Features:

- Solder-Joint conform ASME B16.22
- Forged Brass Body
- Blow Out Proof Stem Design
- Packing Nut, O-RING & Packing On The Stem Seal
- Brass/Chrome Plated Or Stainless Steel Ball
- Handle With Vinyl Grip

Performance Rating:

- 600 psi (WOG) 150 psi (WSP) Service v
- Temperature Range : -20° F to 300° F

Material List:

Part Name	Material
Body	Brass
Seat	PTFE
Ball	Brass/Chrome Plated (1/2" - 1")
	Stainless Steel((1 1/4" - 4")
Stem O-Ring	NBR
Packing Nut	Brass
Stem	Brass (1/2" - 2")
	Stainless Steel(2 1/2" - 4")
Lock Nut	Ferrum /Zinc Plated
Lock Washer	Ferrum /Zinc Plated
Packing	PTFE
Handle	Ferrum /Chrome Plated
Cap	Brass

Approvals:

UL:	1/2" - 4" UL 842 (Guide YRBX,MHKZ)
	1/2" - 4" UL 125 (Guide YSDT,YRPV)
	1/2" - 4" UL 1477 (Guide YQNZ)
FM:	1/2" - 2" per FM1140 for 600psig
CSA:	1/2" - 1" per ASME A118.18.1,CSA B125.1

Dimensions:

SIZE	DN	L	H	W	Cv	Wt.(lbs.)
1/2"	0.591	3.46	1.81	2.17	18.55	0.40
3/4"	0.748	4.29	2.09	2.81	29.76	0.67
1"	0.984	4.29	2.25	3.34	51.55	1.03
1 1/4"	1.259	5.63	2.52	3.91	84.42	1.59
1 1/2"	1.574	5.63	2.74	4.46	131.93	2.28
2"	1.941	5.63	3.03	5.45	200.35	3.48
2 1/2"	2.520	7.76	4.25	6.42	338.43	6.72
3"	2.893	8.19	4.58	7.15	445.44	8.66
4"	3.839	9.25	5.49	9.57	783.88	17.42