

FIG. 122C

CLASS 125 BRONZE Y PATTERN SWING CHECK VALVE SOLDER JOINT ENDS



Features:

- Horizontal Swing type, Solder Joint Ends, Screw Cap, Bronze Body, Disc and Bonnet
- Solder Joint Ends: ANSI B16.18
- 200 PSI non Shock - cold water, oil or gas
- 125 PSI Saturated Steam
- Test pressure: shell (hydro) 300PSI, Seat (hydro) 80PSI
- SS 304 Hinge Pin for 2 ½"-4"

Materials:

No.	Part Name	Specification
1	Body	Bronze C84400
2	Bonnet	Bronze C84400
3	Disc	Bronze C84400
5	Side Plug	Brass C36000
16	Hinge Pin	Brass C36000 - ¼"-2" SS 304 - 2 ½"-4"

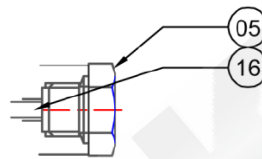
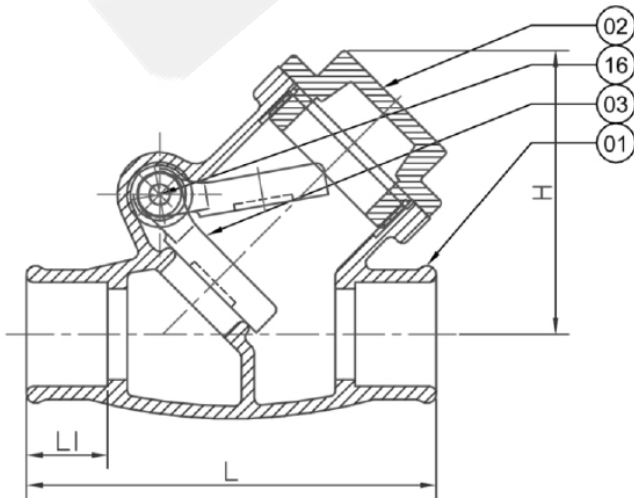

Dimension:

Size		H		L		L1		Weight	
in	mm	in	mm	in	mm	in	mm	lbs.	kg.
½	15	1.7	43	2.17	55	0.49	12.5	0.52	0.25
¾	20	2	51	2.6	66	0.75	19	0.88	0.4
1	25	2.4	61	3	80	0.91	23	1.33	0.6
1 ¼	32	2.8	71	3.62	92	0.96	24.5	2.04	0.9
1 ½	40	3.15	80	4.33	110	1.1	28	2.78	1.3
2	50	3.74	95	5.04	128	1.34	34	4.58	2.1
2 ½	65	4.85	123	6.14	156	1.48	37.5	6.1	2.8
3	80	5.5	140	7.09	180	1.65	42	10.5	4.75